

Diffraction due to surface tension waves on water

Introduction

Formation and propagation of waves on a liquid surface are important and well-studied phenomena. For such waves, the restoring force on the oscillating liquid is partly due to gravity and partly due to surface tension. For wavelengths much smaller than a critical wavelength, λ_c , the effect of gravity is negligible and only surface tension effects need be considered ($\lambda_c = 2\pi \sqrt{\frac{\sigma}{\rho g}}$, where σ is the surface tension, ρ is the density of the liquid and g is the acceleration due to gravity).

In this part, you will study surface tension waves on the surface of a liquid, which have wavelengths smaller than λ_c . Surface tension is a property of liquids due to which the liquid surface behaves like a stretched membrane. When the liquid surface is disturbed, the disturbance propagates as a wave just as on a membrane. An electrically-driven vibrator is used to produce waves on the water surface. When a laser beam is incident at a glancing angle on these surface waves, they act as a reflection grating, producing a well-defined diffraction pattern.

Surface tension waves are damped (their amplitude gradually decreases) as they propagate. This damping is due to the viscosity of the liquid, a property where adjacent layers of a liquid oppose relative motion between them.

Objective

To use diffraction from surface tension waves on water to determine surface tension and viscosity of the given water sample.

List of apparatus

	[1]	Light meter (connected to light sensor assembly)
	[2]	Light sensor assembly mounted on vernier caliper placed on a screen base
	[3]	Tablet computer (used as sine wave generator)
	[4]	Digital multimeter
	[5]	Vibrator control box
	[6]	Wooden platform
	[7]	Track for moving light sensor assembly
	[8]	DC regulated power supply
	[9]	Hex key, measuring tape and plastic scale

Figure 1: Wooden platform unit

	[10]	Scale and rider with vibrator position marker
	[11]	Vibrator assembly
	[12]	Water tray
	[13]	Plastic cover
	[14]	Assembly for adjusting vibrator height
	[15]	Laser source 2 (Wavelength, $\lambda_L = 635 \text{ nm}$, $1 \text{ nm} = 10^{-9} \text{ m}$)
	[17]	500 ml measuring cylinder

Figure 2: Vibrator/laser source unit

Description of apparatus

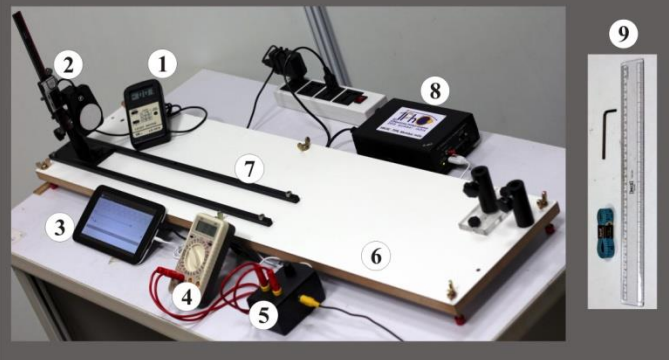
a) Tablet computer as sine wave generator

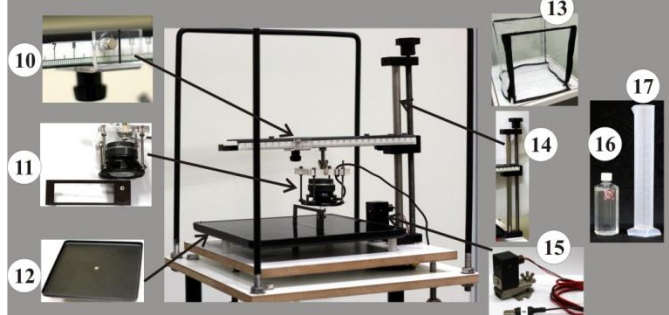
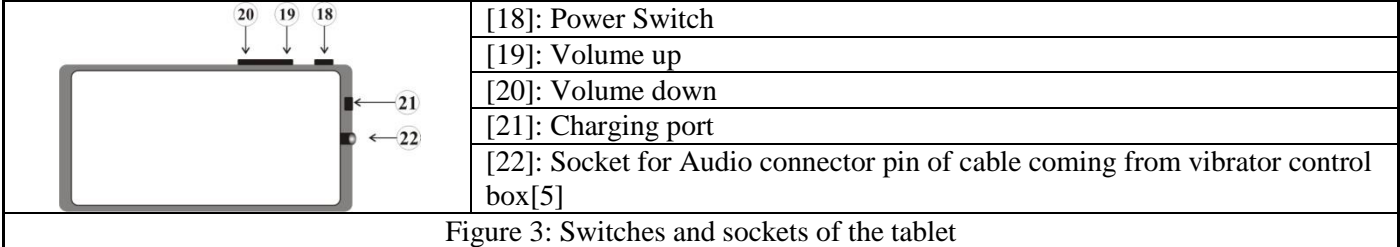

- Note
- Keep the tablet always charging.
 - Gently press the power switch *once* to display initial screen.
 - Keep the output volume at maximum using the “Volume up” button[19].

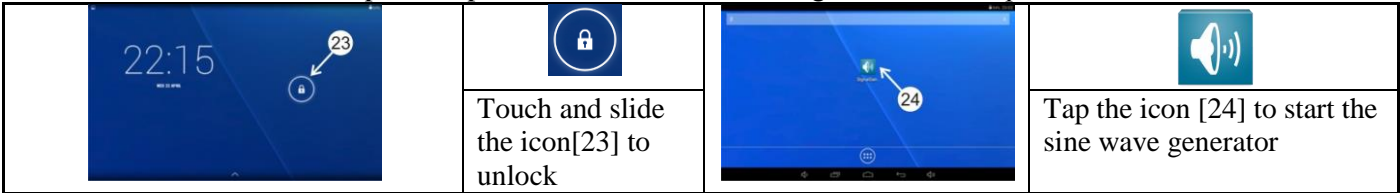

Figure 4: Initial screens of the tablet

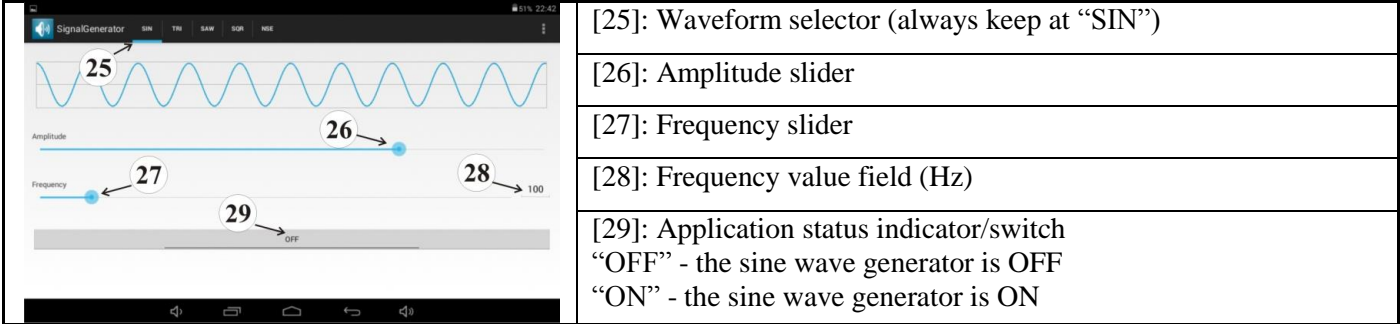

Figure 5: The sine wave generator application

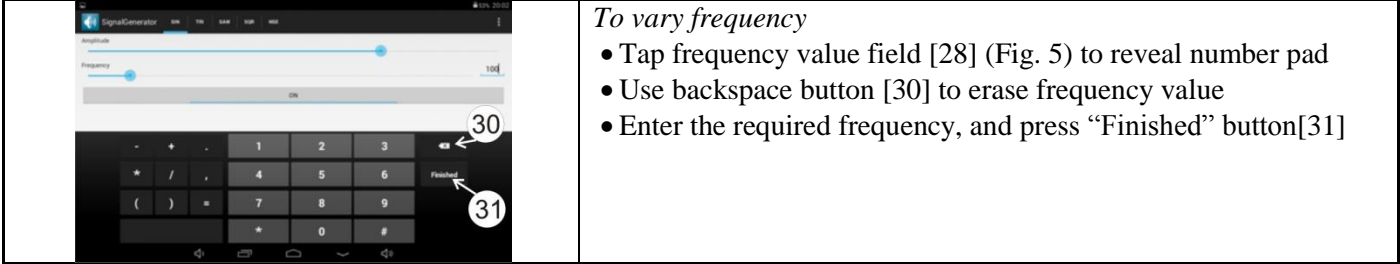
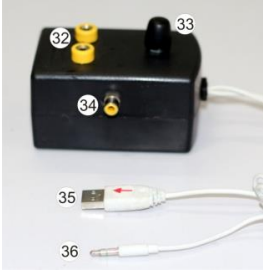

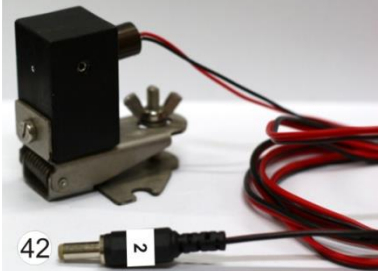







Figure 6: Screen showing number pad to enter frequency value

To vary amplitude



- Use amplitude slider [26] on tablet screen or the variable knob [33] on vibrator control box [5] to vary output amplitude.

b) Vibrator control box, digital multimeter, DC regulated power supply and their connections

		
[32]: Sockets to connect cables from multimeter	[37]: Vibrator strip	Figure 10: Laser source 2 [15] (mounted on a metal block) with connector [42]
[33]: Knob for varying amplitude of the sine wave	[38]: Pin of the cable from vibrator assembly	
[34]: Socket for pin of the cable from the vibrator assembly	Figure 8: Vibrator assembly[11]	
[35]: USB pin to be connected to DC regulated power supply	[39]: AC/DC selector switch	[43]: Intensity switch (keep on “High” position)
[36]: Audio pin to be connected to the tablet	[40]: Range selector knob	[44]: USB socket for USB pin from vibrator control box
	[41]: Input sockets	[45]: Socket for connector from laser source 2
Figure 7: Vibrator control box[5]	Figure 9: Digital multimeter[4]	Figure 11: DC regulated power supply[8]

			
[36]→[22]	[38]→[34]	[41]↔[32]	[35]→[44] and [42]→[45]
Figure 12: Connections between tablet, vibrator control box and DC regulated power supply			

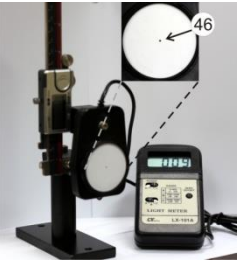
c) Light sensor assembly and light meter

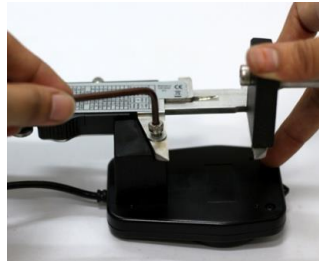
			
[46]: Circular aperture on the light sensor	[47]: Power switch of the light meter	One jaw of the vernier caliper fits into a slot at the back of the light sensor	Tighten the screw using the hex key
[48]: A, B, C – Sensitivity ranges of the light meter	Figure 14: Attaching light sensor assembly		
Figure 13: Light sensor assembly and light meter			

Initial Adjustments

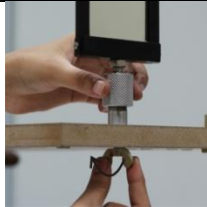
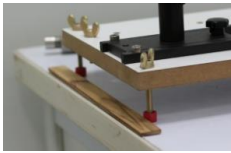
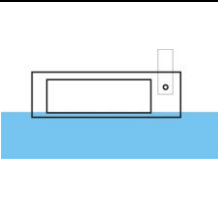
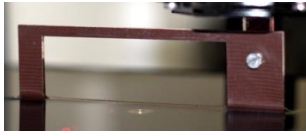
			
Figure 15: Removing the right reflector	Figure 16: Base screws touching the wooden strip	Figure 17: Correct position of the vibrator strip and black knob for height adjustment	

1. Disconnect the laser 1 connector and insert the laser 2 connector into the socket of the DC regulated power supply. Note: Laser 2 has been already adjusted for a specific angle of incidence. Do not touch the laser source!

2. Remove the right reflector used in E-I by turning the bolt under the wooden platform (Fig. 15).

3. Remove the screen used in E-I and insert the light sensor assembly into the screen base. Place the screen base between the guiding rails of the track [7].

4. Position the wooden platform [6] with its base screws touching the wooden strip attached to the working table (Fig. 16).

5. Raise the side flap of the plastic cover on the vibrator/laser source unit. Pour exactly 500 ml of the water sample into the tray [12] using the measuring cylinder [17].

6. Switch on the laser. Locate the reflected laser spot on the light sensor. As you move the light sensor assembly back and forth along the track, the laser spot should move vertically and not at an angle to the vertical. Minor lateral adjustment of the wooden platform and vertical movement of light sensor assembly will allow you to get the laser spot exactly on the aperture. The intensity shown by the light meter will be maximum, if the centre of the laser spot coincides with the centre of the aperture,.

7. The vibrator strip has already been arranged in the correct vertical position. **Do NOT adjust** the black knob of the height adjustment assembly [14] (Fig. 17).

8. The vibrator assembly can be moved back and forth horizontally. Vibrator position marker indicates the position of the assembly on the scale [10].

9. While recording data, keep the flap of the plastic cover lowered in order to protect the water surface from air currents.

Experiment

Part C: Measurement of angle θ between the laser beam and the water surface

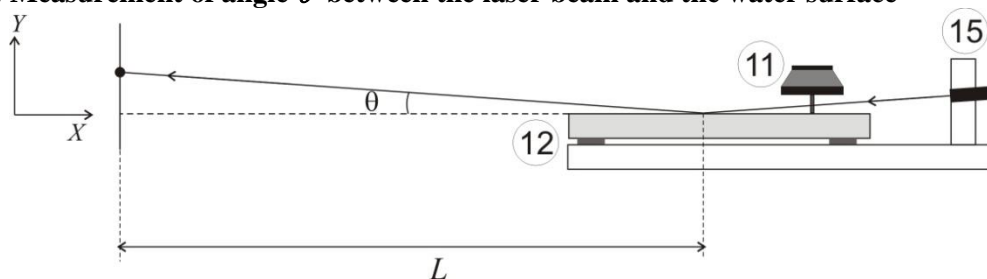

Figure 18: Measurement of angle θ

Tasks	Description	Marks
C1	Move the light sensor assembly in suitable steps along the track. Note down the X–displacement of the assembly and the corresponding Y–displacement of the laser spot. Record your readings in Table C1. (Select appropriate range in the light meter.)	1.0
C2	Plot a suitable graph (label it Graph C1) and determine the angle θ in degrees from its slope.	0.6

Part D: Determination of surface tension σ of the given water sample

From diffraction theory it can be shown that

$$k = \frac{2\pi}{\lambda_L} \sin\theta \sin\gamma \tag{1}$$

where, $k = 2\pi/\lambda_w$ is the wave number of the surface tension waves,

λ_w and λ_L being the wavelengths of the surface tension waves and the laser respectively.

The angle γ is the angular distance between the central maximum and the first-order maximum (Fig. 19).

The vibration frequency (f) of the waves is related to the wave number k by

$$\omega = \sqrt{\frac{\sigma}{\rho}} k^q \tag{2}$$

where, $\omega = 2\pi f$, ρ is the density of the water and q is an integer.

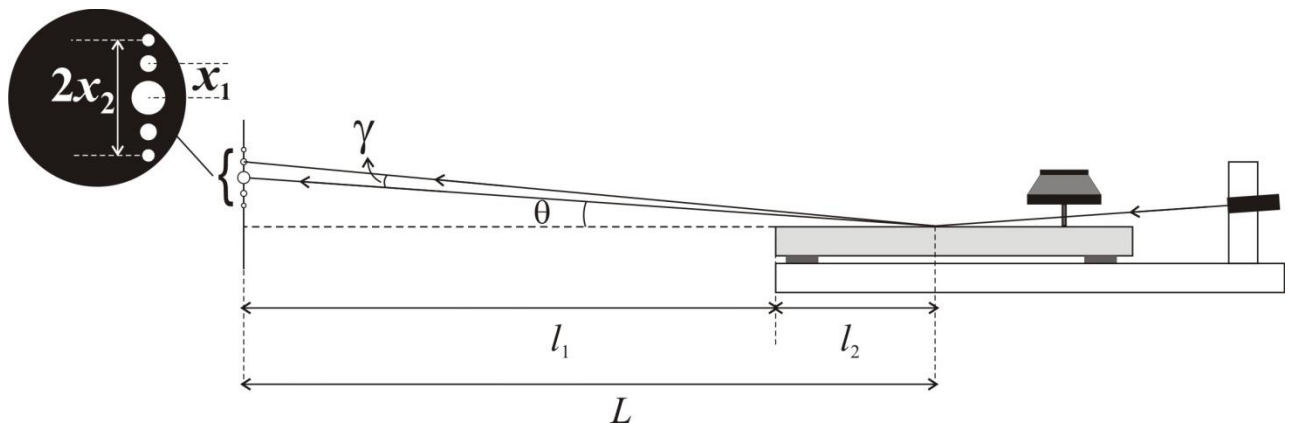

Figure 19: Schematic diagram of the apparatus

- Fix the light sensor assembly [2] (using the tightening bolt at the screen base) at the end of the rails in the position shown in Fig. 1. Select the appropriate range on the light meter.

Task	Description	Marks
D1	Measure the length l_1 between the light sensor aperture and outer edge of the water tray. You will see a line where the laser strikes the water surface. The centre of this line is the point of incidence of the laser. Measure l_2 , the distance of this point from the edge. Obtain L . Record it on your answersheet.	0.3

- Set the vibrator position marker at 7.0 cm mark on the horizontal scale [10].
- Set the sine wave frequency to 60 Hz and adjust its amplitude such that the first- and second-order maxima of the diffraction pattern are clearly visible (Fig. 19 inset).

Tasks	Description	Marks
D2	Measure the distance between the second-order maximum above and below the central maximum. Hence calculate x_1 . Record your observations in Table D1. Repeat this by increasing the frequencies in appropriate steps.	2.8
D3	Identify the appropriate variables for a suitable graph whose slope would give the value of q . Enter the variable values in Table D2. Plot the graph to find q (label it Graph D1). Write down equation 2 with the appropriate integer value of q .	0.9
D4	From the equation 2, identify the appropriate variables for a suitable graph whose slope would give the value of σ . Enter the variable values in Table D3. Plot the graph to determine σ (label it Graph D2). ($\rho = 1000 \text{ kg.m}^{-3}$).	1.2

Part E: Determination of the attenuation constant, δ and the viscosity of the liquid, η

The surface tension waves are damped due to the viscosity of water. The wave amplitude, h , decreases exponentially with the distance, s , measured from the vibrator,

$$h = h_0 e^{-\delta s} \quad (3)$$

where, h_0 is the amplitude at the vibrator position and δ is the attenuation constant.

Experimentally, amplitude h_0 can be related to the voltage (V_{rms}) applied to the vibrator assembly as,

$$h_0 \propto (V_{\text{rms}})^{0.4} \quad (4)$$

The attenuation constant is related to the viscosity of the liquid as

$$\delta = \frac{8 \pi \eta f}{3 \sigma} \quad (5)$$

where, η is the viscosity of the liquid.

1. Set the vibrator position marker at 8.0 cm.
2. Adjust the frequency to 100 Hz.
3. Adjust the light sensor using the vernier caliper such that the first-order maximum of the diffraction pattern falls on the aperture.
4. Adjust the amplitude of sine wave (V_{rms}) such that the reading in the light meter is 100 on range A. Note down V_{rms} corresponding to the light meter reading.
5. Move the vibrator away from the point of incidence of the laser in steps of 0.5 cm and adjust V_{rms} to get the light meter reading 100. Note down corresponding V_{rms} .

Tasks	Description	Marks
E1	Record your data for every step in Table E1.	1.9
E2	Plot a suitable graph (label it Graph E1) and determine the attenuation constant δ from its slope.	1.0
E3	Calculate the viscosity η of the given water sample.	0.3